



RAIN DETECTOR

DESCRIPTION

The **HD2013.2** is a rain detector based on the capacity principle. The capacity value of the sensitive element, on an alumina rest, changes according to the surface dampened by raindrops. An integrated heater keeps it dry, evaporates water and prevents false signals caused by fog or dew. The heater also activates at low temperatures, melting the snow and allowing to detect snow precipitations. The instrument external circular dome acts as a windshield for the sensor, preventing false indications. The instrument is equipped with three different outputs: a "Rain ON/OFF" output, which detects whether it is raining/snowing (ON) or not (OFF), also used to control a relay coil or similar devices; a 0...1V voltage analogue output (calibrated) and a 1,5...6KHz frequency output (not calibrated), which provide an accurate indication of current precipitation intensity. The ON/OFF output comes with a delay circuit that indicates the "rain over" condition with a 2 minute delay, so that the "rain over" condition is distinguished from the "light rain" one. The heater can be disabled when power consumption is critical. To do it, set the Heater OFF input on OV. If requested when ordering, a bird spike, consisting of a 6-spike ring (spike height: 60mm, diameter: 3 mm), can be mounted.

Typical Applications

The rain detector can be used either as a separate device, or connected to a data logger system (for example: in a weather station). In figure 1, the HD2013.2 ON/OFF output is connected to a relay coil that powers an engine: should it rain, the ON/OFF output will energize the relay coil, which will close the normally open contact (in this case the rain detector is employed as part of a control system, such as, for example, for closing windows). Warning: when the HD2013.2 is connected to a relay coil, use always a protection diode, as shown in figure 1.

Installation and Maintenance

Place the detector far from buildings, trees, etc..., taking care that no object is over the detector, as it might prevent rain detection. Use the supplied accessories to mount the instrument; the bracket can be fixed to a post having a diameter from 30 to 50mm; the post can be either horizontal or vertical thanks to the bracket double drilling. A standard 5-m cable is supplied for the electrical connection with an IP68 connector to be inserted at the bottom of the instrument: the colours of the leads and the relating functions are to be found in the technical specifications. To ensure good immunity from noises, it is recommended to connect the cable braid to the earth and to keep the heater and the electronics earth leads separate. Clean the sensor regularly with a cotton flock soaked in distilled water; in case of ingrained dirt, mild cleansers can be used in moderation.

The sensor is fragile, as it is placed on an alumina rest, thus handle it with care!

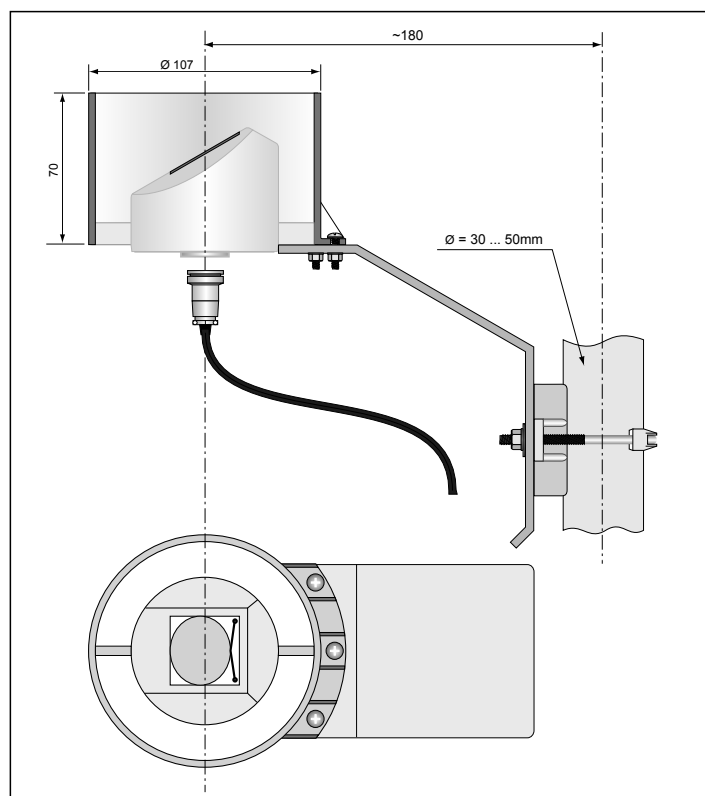

Technical Data/Specifications

Sensor	
Type	Capacitive, with integrated heater
Sensor	6.6cm ²
Angle	30°
Sensitivity	
Min. sensitive area	0.05cm ²
ON delay/Trip delay (OFF>>ON)	< 0.1ms
OFF delay/Shut-off delay (ON>>OFF)	< 5min
Dimensions	
Diam. x height	ø107 x 70 mm
Weight	450g
Cable length	5m (other lengths available on request)
Material	BASF LURAN S777K
Electrical Features	
<i>Power Supply</i>	
Supply Voltage	12Vdc ± 10%
Current Consumption	130mA (typical) 230mA (max) 10mA (with heater disabled)
Sensor Power Consumption	0.5 ... 2.3W
<i>Outputs</i>	
Rain ON/OFF	Open collector, closed in case of rain.
Max. Voltage	15V
Max. Current	50mA
Analogue Output	0...1V (0V = rain, 1V = dry sensor)
Frequency Output	1500 ... 6000Hz (rain ... dry sensor) Not calibrated
<i>Inputs</i>	
Heater OFF	OFF = connected to GND
Closing Contact Capacity	15Vdc, 2mA
Ambient Conditions	
Operating Temperature	-15 ... +55°C
Storage Temperature	-40 ... +65°C

Electrical Connection – Colour Codes

Power supply (+)	Red
Rain ON/OFF	Blue
Heater OFF	Green
Analogue Output	Yellow
Frequency Output	White
Electronics Earth	Black
Heater Earth	Grey

Ordering Codes

HD2013.2: Rain detector equipped with mounting bracket. 8-pole connector output according to IEC 60130-9 **IP68**.

CP2013.2.5: 5-m connection cable: 8-pole IEC 60130-9 IP68 female connector on one end. Other lengths available on request.

HD2013.2D: "Bird spike", consisting of a 6-spike ring (spike height: 60mm, diameter: 3 mm), to be expressly requested when ordering.

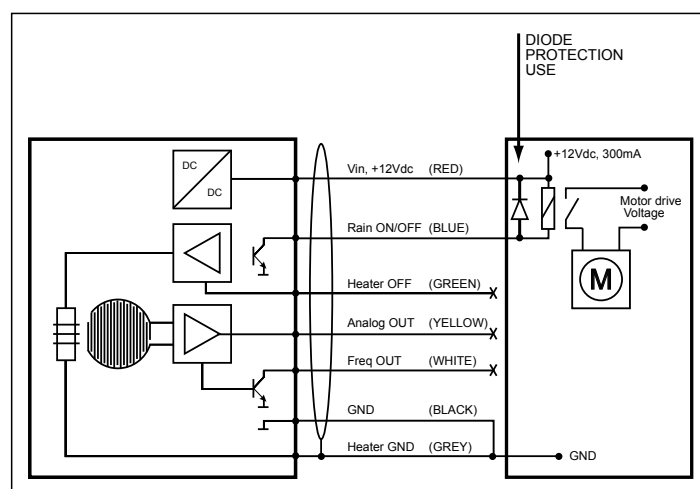

Fig. 1